

Product Information Solenoid Diaphragm Dosing Pump MAGDOS LD

Reliable dosing of chemicals

Solenoid diaphragm dosing pumps play an important role in the reliable and accurate dosing of liquids in process sequences. They are appropriate for low-pressure applications and small dosing quantities.

Dosing pumps are used in many branches of industry that work with liquid chemicals - not excluding toxic and aggressive media.

Wide range of applications

MAGDOS LD is available in seven power ranges. The power ranges cover from 0.5 to 15 l/h with back pressures up to 16 bar. Double-ball valves ensure accurate dosing. To adapt the dosing performance, the stroke frequency can be adjusted manually or via an external control contact. You can thus dose with a flick of the wrist.

Several different materials and connections are available for suction and discharge side, depending on the specific applications. By using appropriate and recommended materials, the MAGDOS LD can be used in most process applications.

A matching accessory set with hoses, injection points and suction lines from our comprehensive accessory range means that nothing stands in the way of a quick installation, and you get the best results.

Simple to use and space-saving

Thanks to the sturdy, low-maintenance solenoid drive, the media being supplied (acids, alkalis, coagulants and flocculants, for example) are reliably and accurately dosed.

The MAGDOS LD doesn't just impress with its elegant design; the graphical display as well as the dosing pump's operation using the integrated keyboard simplifies its use.

The dosing pump is compact and, thanks to the small mounting area, can be integrated into every dosing system in a very space-saving way. It can be mounted in three different positions without further attachments: standing, left- or right-oriented on a wall.

In Short

- Capacity range 0.5 to 15 l/h, up to 16 bar
- Power supply 230 V AC \pm 10 %, 50/60 Hz, IP 65, max. 25 W or 115 V AC \pm 10 %, 50/60 Hz, IP 65, max. 25 W
- Graphical display
- Materials available: PVC, PP and PVDF
- Material consistency for the pumps and accessories
- Dosing head ventilation
- Supplied with connection sets
- Wall and floor mounting
- Double-ball valves ensure accurate dosing
- Precise pump settings using the keyboard
- Input signals through a M12x1 connector
- External control via floating contacts with impulse increase and reduction
- Level input with early warning and main alarm
- Release input



Model variants

MAGDOS	Material		
	PVC	PP	PVDF
LD 05	10241001	10241015	10241008
LD 1	10241002	10241016	10241009
LD 2	10241003	10241017	10241010
LD 4	10241004	10241018	10241011
LD 6	10241005	10241019	10241012
LD 10	10241006	10241020	10241013
LD 15	10241007	10241021	10241014

Cable with M12x1 plug connector, A-coded, 2 m long, open cable end 4-pin is part of the scope of delivery.

Technical data

MAGDOS LD		05	1	2	4	6	10	15	
Delivery capacity at max. pressure	l/h	0.36	0.76	1.9	3.4	6.2	9.0	13.0	
	ml/stroke	0.05	0.05	0.2	0.31	0.57	0.83	0.86	
Max. supply pressure	bar	16				8	6	3	
Delivery capacity at medium pressure	l/h	0.54	1.1	2.3	3.8	6.8	10.0	15.3	
	ml/stroke	0.08	0.08	0.24	0.35	0.63	0.92	1.02	
Average back pressure	bar	8				4	3	1	
Max. stroke frequency	RPM	120	250	160	180		250		
Suction head for non-gassing media	mWS	5		3		2			
Max. inlet pressure	mbar	800							
Nominal valve width		DN3			DN4				
Voltage supply		230 V AC \pm 10%, 50/60 Hz or 115 V AC \pm 10%, 50/60 Hz							
Power consumption	W	8	13	19	25		22		
Protection class		IP 65 (with covering caps on the connections)							
Insulation class		F							
Weight	kg	~ 3.2							
Max. ambient temperature	$^{\circ}$ C	5 - 45 (5 - 40 with PVC parts)							
Max. temperature of the medium	$^{\circ}$ C	80 (with PVC parts 35; with PP parts 60)							

Delivery characteristic curves

The delivery characteristic curves are valid for 20 $^{\circ}$ C (68 $^{\circ}$ F) for water at 100% stroke frequency. The delivery capacity depends on the medium (density and viscosity) and temperature. Dosing pumps must therefore be gauged in litres during application.

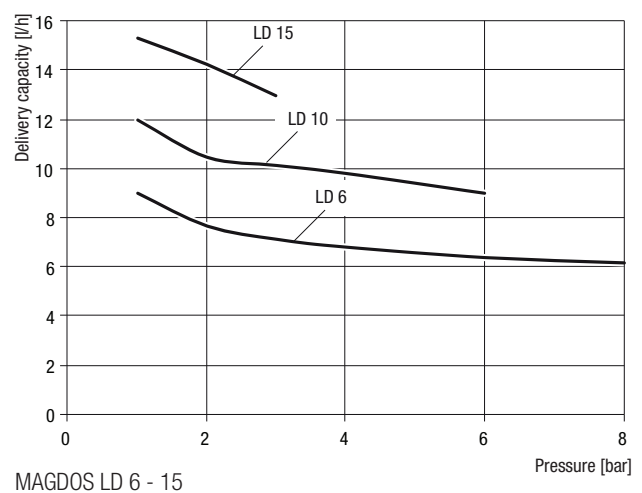
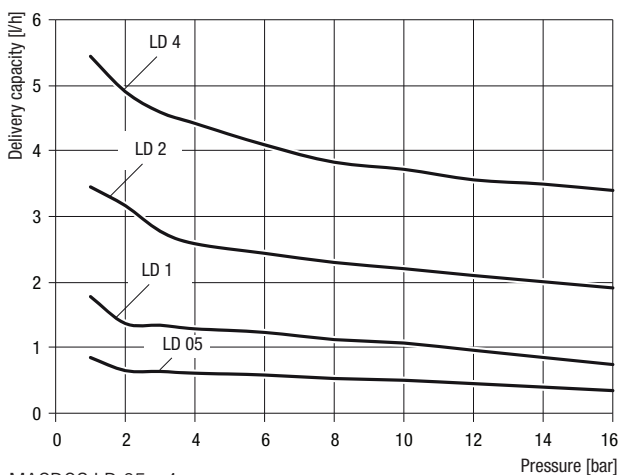

Dimensions

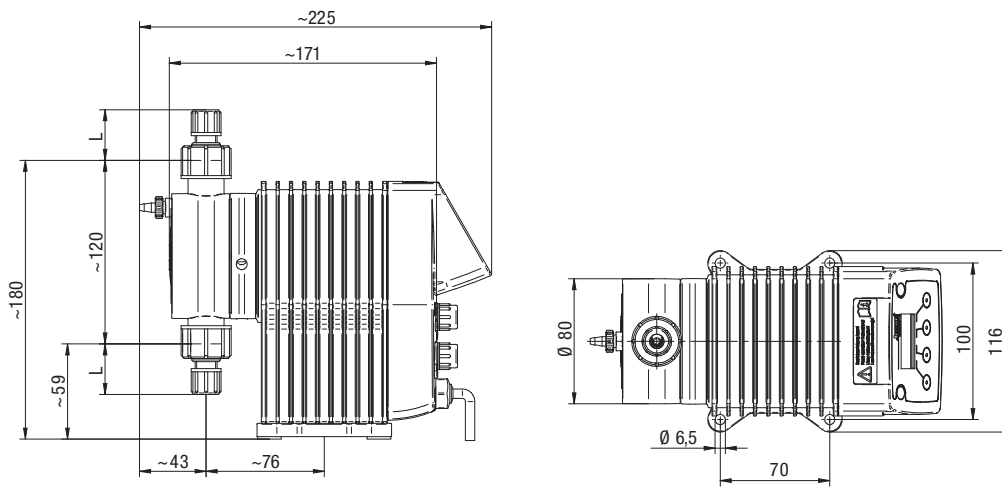

All dimensions in mm

Connection	Material	Size	Nominal diameter	L
Hose clamp connection	PVC, PP, PVDF	4/6 mm	DN4	31 mm
		1/4x3/8"	1/4"	34 mm
		6/9 mm	DN6	34 mm
		6/12 mm	DN6	15 mm

Product Information Solenoid Diaphragm Dosing Pump MAGDOS LD

Accessories

Suitable sets of accessories, which consists of a suction line, a pressure line and an injection nozzle, are available for the dosing pumps.

Even the best pump can still be improved - namely by the right technical periphery.

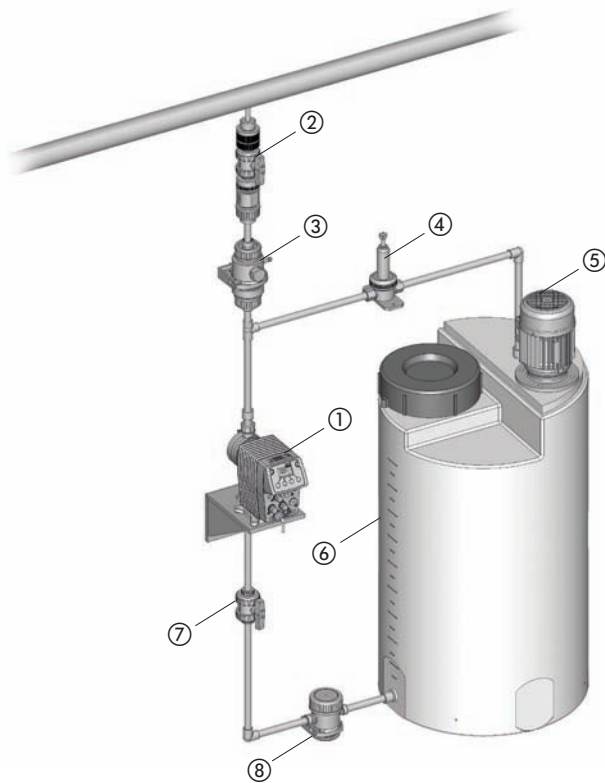

To make your dosing pump into an efficient dosing system, we recommend using the following accessories:

- Injection nozzles – to dose the medium in the main line and to prevent it flowing back into the pressure line
- Pressure loading and relief valves – to increase dosing accuracy or to protect the system against too high a pressure
- Pulsation dampener – to damp supply currents as well as to reduce the flow resistance in long pipelines.
- Priming aids – to significantly ease priming of dosing pumps with low supply volumes per stroke, for large suction heights, for highly-viscous dosing media or for initial priming or when priming after the system has been laying idle
- Suction pressure regulator – to prevent medium flow when the dosing pump is not running or to prevent a vacuum being formed in the event of a pipe burst

For further accessories for your dosing pump, please refer to our dosing pump brochure.

Legend

- | | |
|--|------------------------------|
| ① MAGDOS LD | ⑤ Electrical agitator |
| ② Injection nozzle with shut-off valve | ⑥ Dosing tank |
| ③ Pulsation dampener | ⑦ Shut-off valve |
| ④ Pressure relief valve | ⑧ Suction pressure regulator |