

General

Liquid chlorine requires about 270 kJ per kg to change from the liquid state into chlorine gas. For containers holding liquid chlorine such as cylinders and drums this means that about 1 - 2% of the total content can be removed as gas per hour. If more gas is withdrawn for a longer period of time, undercooling and eventually icing of the container would be the result. As a consequence, there would be an important pressure loss in the container causing the interruption of the chlorine supply. Taking an average quantity of 1% chlorine gas withdrawn per hour as a basis, the number of cylinders and drums to be connected in parallel can be determined. This method is only practical for volumes of up to 25 kg chlorine gas per hour which corresponds to 2,500kg liquid supply. As two batteries of the same size which can be connected alternately should be installed to ensure a continuous supply, the storage of chlorine gas becomes uneconomically high. Thus forced evaporation is recommended if larger quantities of chlorine are required.

The chlorine evaporator C 6100 has a heating element which in a simple and economical method converts up to 220 kg/h of liquid chlorine into chlorine gas. Thus the chlorine supply system must only be dimensioned so that the containers can be changed at reasonable intervals.

Applications

Chlorine evaporators are mainly used in water treatment plants of cooling water systems for power plants, large factories, petrochemical installations as well as waste water treatment plants. Aluminium processing plants also need large quantities of chlorine gas.

Function

The chlorine evaporator mainly consists of a tubular coil immersed in a temperature-controlled hot water bath. The hot water bath is kept at a constant level by a solenoid valve while the minimum level is monitored by an alarm electrode. Electrical heating rods are normally used for heating. The temperature is regulated to a value adjustable between 68 - 76°C by a contact thermometer. This contact thermometer fitted at the front panel also shows the actual temperature.

For extra safety the chlorine evaporator has two extra thermostats for the minimum and maximum temperature. The contacts respond when the temperature drops below 60°C or exceeds 80°C, and are processed as control and monitoring functions in the separate switch cabinet. The pressure in the tubular evaporator coil is the same as the saturated vapor pressure which in turn corresponds to the storage temperature of the chlorine supply container. The chlorine evaporator is therefore not subject to the risk of excess pressure, even if the water should start to boil due to the failure of all monitoring functions.



Safety devices

Unacceptably high pressures can only occur if the chlorine evaporator is filled with liquid chlorine under cold, unheated conditions. If then the inlet and outlet valves are closed and the heating is switched on, the chlorine naturally expands to an extent which would cause an inadmissibly high pressure - provided that no rupture disk or spring-loaded safety valve was installed directly at the outlet of the chlorine evaporator.

Any chlorine escaping at this point is collected in an empty container (size of a normal drum of about 400 kg) in order to expand to a pressure suitable for the system. A contact pressure gauge fitted at the front panel measures the chlorine gas pressure and makes contact if the admissible operating pressure is exceeded (switching the heater off).

Protection against corrosion

The steel parts of the chlorine evaporator are galvanically protected against corrosion by magnesium electrodes with a service life of approximately one year.

Functional diagram

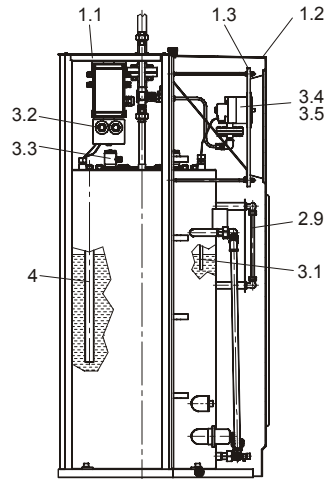
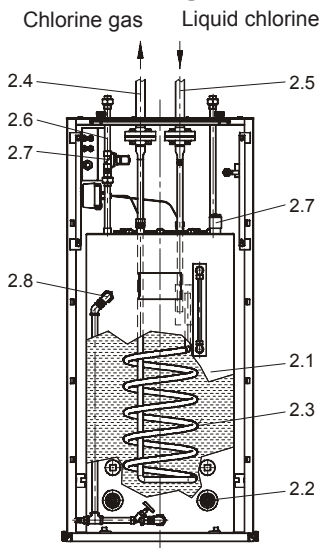

- 1.1 Frame
- 1.2 Cover
- 1.3 Front panel

- 2.1 Hot water tank
- 2.2 Heater elements
- 2.3 Evaporator coil
- 2.4 Connection for chlorine gas
- 2.5 Connection for liquid chlorine
- 2.6 Water connection
- 2.7 Solenoid valve with 3-rod level electrode
- 2.8 Overflow safety device
- 2.9 Water level gauge

- 3.1 Temperature sensor
- 3.2 Thermostats for min. and max. temperature monitoring
- 3.3 Level electrode
- 3.4 Contact thermometer for controlling the temperature of the hot water tank
- 3.5 Contact gauge for max. chlorine gas pressure

- 4. Cathodic protection (magnesium electrodes)

Control

The thermostats, contact thermometers and contact pressure gauges as well as the level electrodes are connected to a terminal box inside the evaporator. The heater elements are operated by limit contactors in a separate switch cabinet. The switch cabinet is not part of the scope of delivery. The control unit must be produced on site or ordered separately (Part No. 40210009).

Circuit diagram

Normally wiring is done from this terminal box to a separate switch cabinet which accommodates the control of the evaporator as well as of the whole chlorine system. The control process is set up individually depending the customer's requirements.

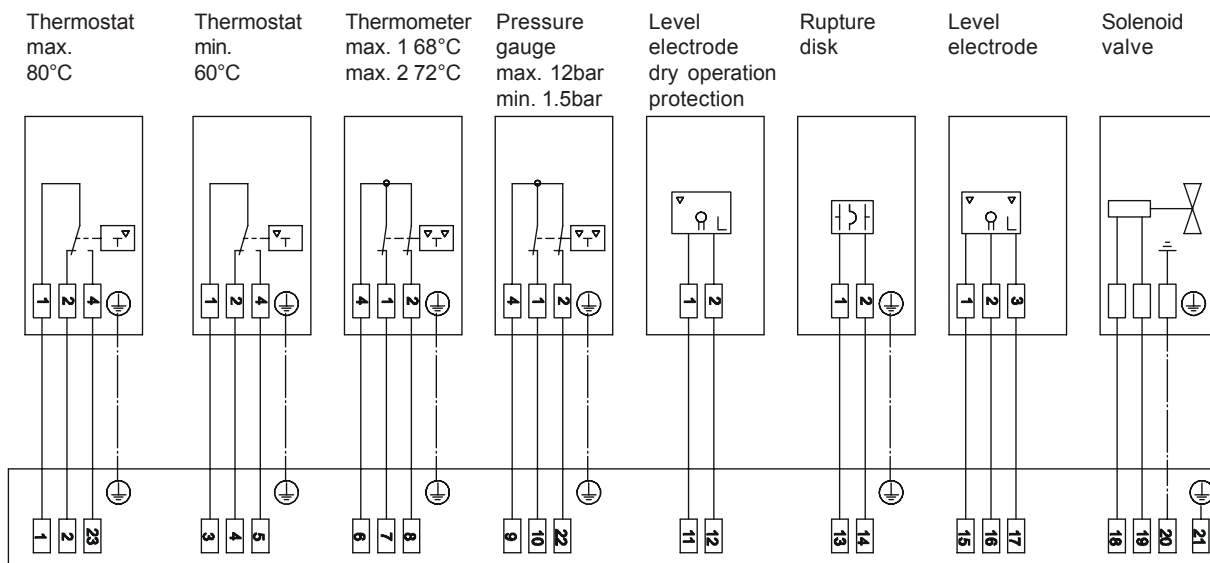

Terminal box in chlorine evaporator.

Technical Data

Design:	Epoxy resin-coated steel frame construction with plastic cover
Heat transfer:	Tubular coil immersed in hot water tank.
Coil volume:	for 65 kg/h : approx. 1l for 220 kg/h : approx. 9l
Hot water tank:	Contents approx. 175l
Heating:	Electrical elements 220/380 V, 50Hz (max. 500V), 5 kW for 65 kg/h Cl ₂ : 10 kW for 220 kg/h Cl ₂ : 20 kW

The available heating capacity is designed to allow for quick starting. The actual energy consumption corresponds to the quantity of chlorine to be evaporated.

Control and monitoring equipment:	Refer to functional and circuit diagram.
-----------------------------------	--

Part Numbers

65 kg/h unit	:	20528666
220 kg/h unit	:	20528667
Switch cabinet	:	40210009

Accessories

Dimensions

Connections : flanges DIN 2512 (groove-and-tongue joint) DN 25 / PN 16
delivery includes counterflange with internal thread G1

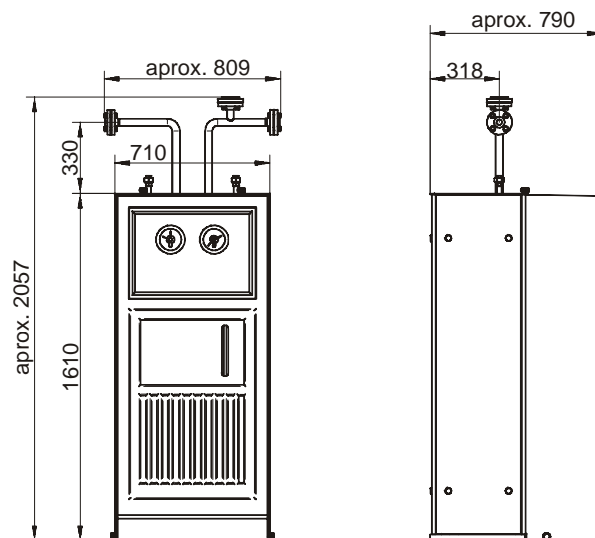

	Part No.
Rupture disk with support as intermediate flange design (DIN2512 / DN25 / PN16) for direct connection on flange connection. (bursting limit 16 bar)	78770
Spare rupture disk (bursting limit 16 bar)	78769
Warning rupture disk is mounted together with the rupture disk, the contact is broken on response.	78771
Safety valve spring-loaded, with flange connections DIN2512 / DN25 / PN16 reponse pressure 15.5 bar	88022
Contact pressure gauge 0...16 bar NG100 with max break contact (freely adjustable); connection G 1/2 bottom other pressure gauges see MB 2 40 01	24087342
Quick shutoff valve to protect the connected metering units against liquid chlorine in the case of an evaporator failure. Ball valve with flange connections DIN2512 / DN25 / PN16 pneumatically with spring return incl. pilot valve 230V / 50Hz electrically 230V / 50 Hz with accumulator return in the case of a voltage failure	20500003 20500004
Flanges for chlorine piping according to DIN2512 / DN25 / PN16 (groove-and-tongue joint) with internal thread G1	
Flange with groove	15791
Flange with tongue	15790
fitting gasket	81421
Maintenance kit for chlorine evaporator C6100 with all required seals, sacrificial (protective) anode and pressure gauge piping with ball valve	20500005

Chlorine evaporator control

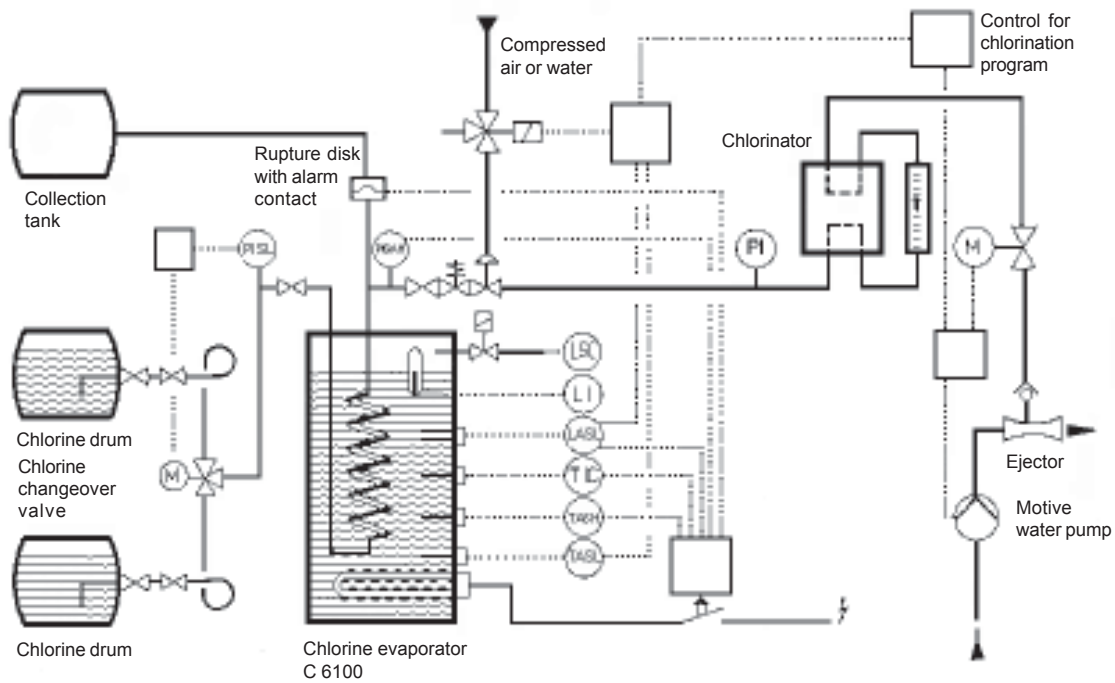

Legend

- LSC Level control
- LI Level indicator
- LASL Low level alarm
- TIC Contact thermometer with min. and max. contact
- TASH Temperature max. alarm
- TASL Temperature min.alarm
- PI Pressure gauge
- PISL Pressure gauge with min. contact
- PISAH Contact pressure gauge with max. contact